

# Detector Switch ( Lever Type )

## MLS Series

### Feature

- ◇ This switch is a light movement with small type.
- ◇ Crossbar contact point is used.
- ◇ Wide lever-variation.

### Applications

- ◇ Mechanism for general audio and car audio products.
- ◇ FAX, Label printer
- ◇ For various kind of low current switching use.



MLS-129AU



MLS-129AUS6

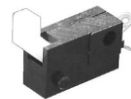

MLS-132AU



MLS-142AU

### Products Line

No	Products No	Poles	Positions	Operating force
1	MLS-129AU	1	1	0.69N max
2	MLS-129AUS6	1	1	0.69N max
3	MLS-132AU	1	1	0.69N max
4	MLS-142AU	1	1	0.29N max

MLS-129AU and MLS-129AUS6 have different contact points.

### Typical Specifications

Items	Specifications
Ratings (max) (Resistive load)	20mA 16V DC (Resistive load)
Contact resistance	50 milliohm max
Insulation resistance	50 megohm min. 250V DC
Withstanding voltage	250V AC for 1min
Operating life	20,000 cycles

Dimensions

Unit : mm

No	Style	P.C.B reference Land Dimensions Circuit Diagram
1	<p>MLS-129AU</p>	
2	<p>MLS-129AUS6</p>	

Dimensions

Unit : mm

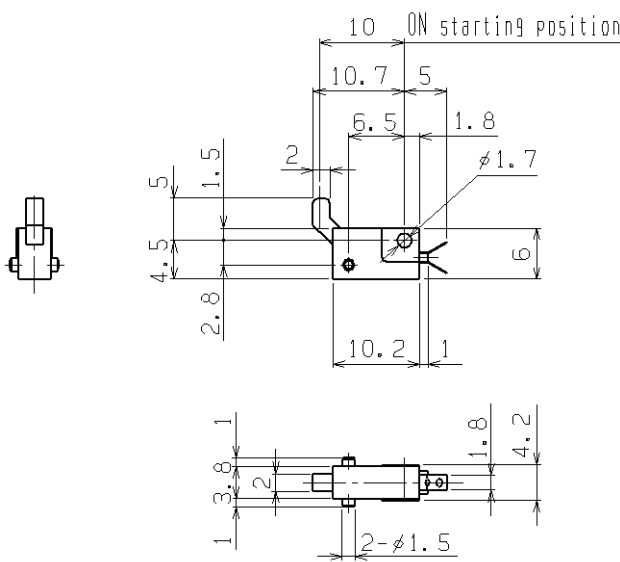
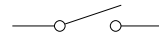
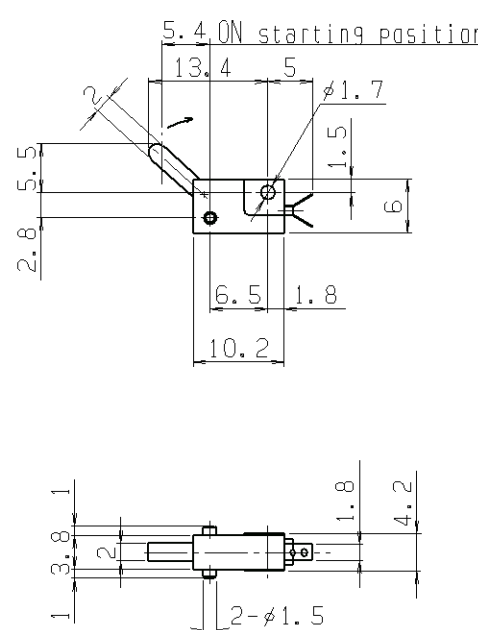
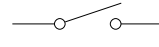
No	Style	P.C.B reference Land Dimensions Circuit Diagram (TOP VIEW)
3	<p>MLS-132AU</p> 	
4	<p>MLS-142AU</p> 	

## □ Notes

1. The appearance and specifications of the product may be modified without prior notice to improve its performance.
2. This catalog shows only outline specifications. When using the product, please obtain formal specifications supply.
3. Please see appendix [Cautions in Using Switches].
4. For high safety applications, please confirm with protection and redundant circuit.
5. This detector switch is not a washable type.
6. In manual soldering, consideration should be given to apply the soldering iron to the tip of the terminal so that unusual pressure is not applied to the terminal.
7. Please do not apply pressure for 1 minute after soldering.
8. Since soldering quality may deteriorate due to sulfuration and oxidation of terminals, please use as soon as possible within maximum 6 months after delivery and use within a after opening the package condition and the one within 1 week after you unpack it again.
9. Please confirm the performance on actual operation by simulation with actual environment environments for high reliability.